

Design and Development of Radar Controller for 2D Air Surveillance Radar RAWL 02 MK-II A

Anusha M¹, Sharath L², Hanamant V M³

^{1,2}D&E/RS-Naval Systems-2, Bharat Electronics Ltd., Jalahalli P O, Bangalore-560013,

³BSTC/C-D&E, Bharat Electronics Ltd., Jalahalli P O, Bangalore-560013

anusham@bel.co.in

Abstract:

Radar Controller is a comprehensive touch-screen based GUI application designed and developed for Radar RAWL-02 MK-II A operation and status monitoring. Radar Controller is an advanced application which is self-sufficient with its flexible architecture, wide-range of non-interfering and parallel-executing functionalities, user-friendly GUI, easily accessible in-built tools and well-designed look and feel to support Radar operation. RC application can be adopted for operation of similar Radars.

I INTRODUCTION

RAWL 02 MK-II A is solid-state 2D air surveillance Radar operating in L-Band. The Radar operation and status monitoring is through a comprehensive GUI application ported on Intel® 3rd Gen Core™ i7 Rugged Computer. Radar Controller (RC) serves as the Master controller, controlling thirteen functional subsystems (Figure 1) present in the Radar i.e. Antenna, Antenna Control Unit (ACU), Power Distribution Unit (PDU), Solid State Power Amplifier (SSPA), SSPA Power Supply, Waveform and Timing Generation Module (WTG), Sensitivity Time Control (STC), Receiver control hardware (SLC), Signal Processor (SP), Centroider, Radar Monitor, Chiller unit, and Waveguide Drier through UDP Broadcast for quick response.

RC is a touch-screen based **cross platform** GUI application which comprises of GUI layer, Communication layer, Data layer and Processing layer, all in a single application. RC application works on both Red Hat Enterprise Linux (RHEL 6.x) and Windows operating systems. RC application is developed on Qt Development Toolkit to make the application compatible with different operating systems and for enhanced look and feel.

The Radar is configured with standard interfaces like Ethernet, RS-232, RS-422 and RS-485 to make the status available on RC GUI via LAN. RC is a real-time application which periodically monitors status of Radar subsystems through status request and facilitates Radar operation through controls. Master/Slave (Figure 3) configuration is implemented to facilitate local and remote control of the Radar. Local RC is a part of the Radar hardware and Remote RC is located at a remote location away from the Radar. Master/Slave configuration enables seamless handover of Master control and exchange of last operating parameters between the two RC applications.

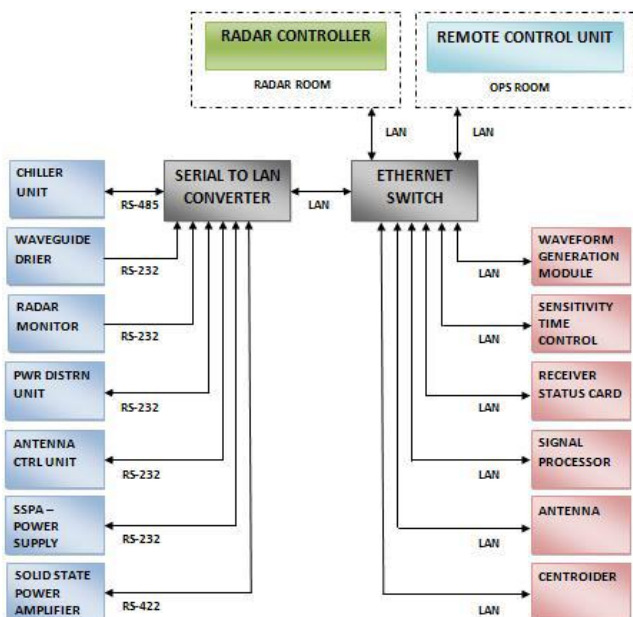

Figure 1 RAWL-02 MK-II A Radar Communication Architecture

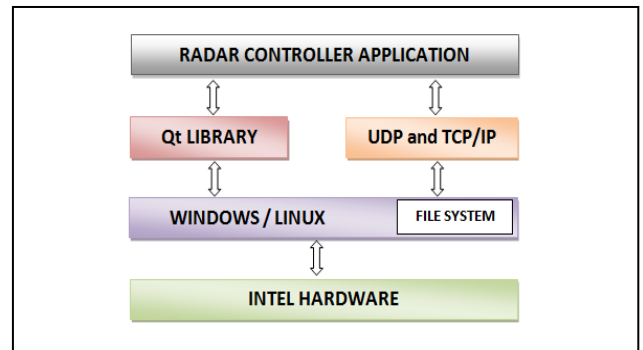

Figure 2 Design Architecture of Radar Controller

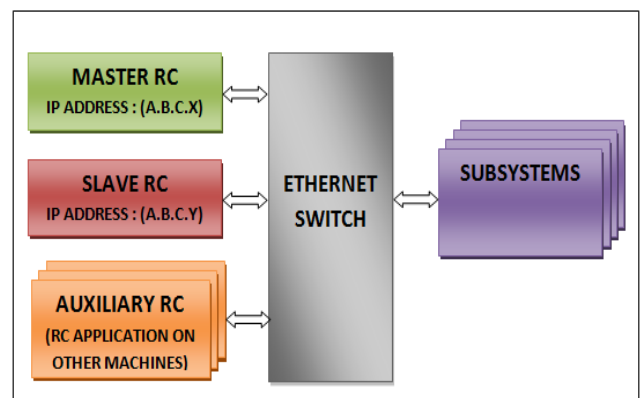

Figure 3 Master / Slave Architecture of Radar Controller

II RADAR CONTROLLER GUI APPLICATION

The Graphical User Interface of RC is categorized based on the functional status and controls of various subsystems to enable control and display of status. 'Controls' comprise of Main page, STC-Selection page and Admin page. 'Status display' comprises of Status pages for various subsystems, Measurements page, BITE page and Logs.

1 Main page

All operational controls of the Radar are made available to the operator in a single view in the form of Main page to enable Radar operation through commands and controls to Radar subsystems. The readiness of the System for operation is indicated here.

Main page (Figure 4) facilitates the User to select Long range / Medium range, Antenna / Dummy Load, Fixed frequency channel / Burst to burst frequency agility / Pseudo random frequency agility, selection of operation features like 'Interface suppression' and 'Pulse length discrimination', switching ON / OFF Antenna, 'Sector Transmission' selection with 'sector width' and 'sector centre', and finally switching ON/OFF Radar transmission. Main page provides provision to reset all the Radar parameters through RESET button.

Main page displays the present state of the Radar and overall status of Radar subsystems in terms of colour indications, number of radiated hours in textual form, and status of important Radar control parameters, interlock parameters and measured values in tabular form.

2 STC - Selection page

'Sensitivity Time Control' is implemented in the Receiver front-end comprising of Low Noise Amplifier (LNA) and TR limiter to avoid Receiver saturation because of high reflection due to nearby strong targets. Provision exists to configure the amplitude, pulse width and slope for generation of STC pulses separately for both long and short pulse. This feature facilitates to control the gain of LNA as per the current target scenario and to apply optimum attenuation to allow the long range weak targets to be processed while suppressing nearby strong clutter.

STC – Selection page (Figure 5) provides STC – LNA controls for configuration such as amplitude in Volt, constant range in km, variable range in km OR function in terms of R^2 , R^3 and R^4 for both land-side and sea-side settings w.r.t. both Main and SLS channels. STC – Selection page also displays the configured values in the form of graph to provide better understanding to the User. 'STC Scale' is made available to map the configured amplitude value to corresponding attenuation in dB.

3 Admin page

Critical operational, configuration and processing parameters of the Radar for fine-tuning of the System output are made available under Admin privileges. Admin controls comprise of signal processing parameters such as MTI and CFAR thresholds, MTI selection, CFAR selection, PRF mode etc to be configured after assessing the target scenario. The controls such as MTI threshold and MTI range selection along with canceller selection are configured for enhancing the MTI performance. Admin controls (Figure 6) are available through **password protection** to allow access only

for the operators with the knowledge of configuring these parameters.

Admin page is also facilitated with various important in-built tools to enable configuration, calibration, monitoring and troubleshooting of errors. Admin privileges include provision to configure STC – TRL related parameters and the set of frequency values for operation, calibrate receiver chain (dynamic plot calibration and single point calibration), view and edit wide-range of configuration xml files used by RC, view the content of UDP packets received from subsystems, configure Centroider parameters and also change the password used for accessing the Admin page.



Figure 4 RC GUI Main page



Figure 5 RC GUI STC – Selection page



Figure 6 RC GUI Admin page

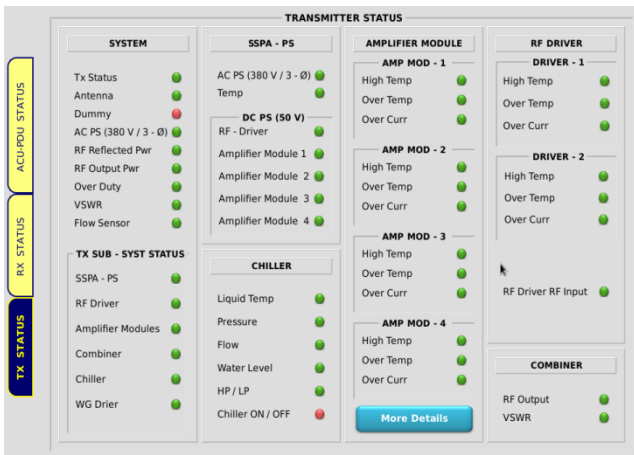

Figure 7 RC GUI Transmitter status page

PARAMETERS	UNIT	MEASURED VALUES	RANGE	STATUS
Receiver				
UP-Conv-OP	dBm	13.00	(2 to 15)	OK
UP-Conv-IP	dBm	-11.00	(-16 to -5)	OK
LO-1-OutPut	dBm	17.50	(14.0 to 20.0)	OK
LO-2-OutPut	dBm	17.50	(12.0 to 20.0)	OK
LO-3-OutPut	dBm	12.00	(10.0 to 13.0)	OK
Synthesizer-Fixed-Frequency	MHz	NA	NA	NA
RPSU-1PS-1(+5.5V)Rx	V	5.50	(5 to 6)	OK
RPSU-1PS-2(+15V)Rx	V	15.00	(14.5 to 15.5)	OK
RPSU-1PS3(+5V)Rx	V	5.00	(4.5 to 5.5)	OK
RPSU-1PS4(+5V)WTG-SDU	V	5.00	(4.5 to 5.5)	OK
RPSU-1PS5(+5V)STC-SDU	V	5.00	(4.5 to 5.5)	OK
RPSU-2PS1(+15 V)SDU	V	15.00	(14.5 to 15.5)	OK
RPSU-2PS2(+5V)SDU	V	5.00	(4.5 to 5.5)	OK
RPSU-2PS3(-15V)SDU	V	-15.00	(-15.5 to -14.5)	OK
RPSU-2PS4(+5V)SP	V	5.00	(4.5 to 5.5)	OK
RPSU-2PS5(+5V)SP	V	5.00	(4.5 to 5.5)	OK
Lna-Assembly-PS	V	5.00	(4.5 to 5.5)	OK

Figure 8 RC GUI Measurements page

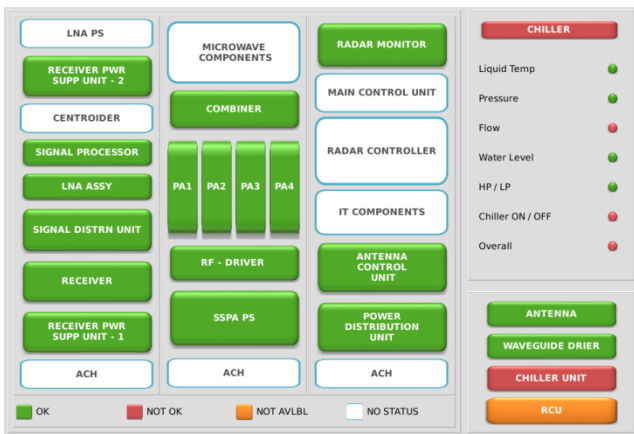

Figure 9 RC GUI BITE page

File	Variable	Function	PC2	Variable Range
SLS STC LNA MED RANGE	Variable	Function	PC2	: VARIABLE RANGE
STC TR1 LONG RANGE	PC1 Amplitude (V)			: 5
STC TR1 LONG RANGE	PC1 Pulse width extended (us)			: 5
STC TR1 MED RANGE	PC1 Amplitude (V)			: 5
STC TR1 MED RANGE	PC1 Pulse width extended (us)			: 5
STC TR1 LONG RANGE	PC2 Amplitude (V)			: 5
STC TR1 LONG RANGE	PC2 Pulse width extended (us)			: 160
STC TR1 MED RANGE	PC2 Amplitude (V)			: 5
STC TR1 MED RANGE	PC2 Pulse width extended (us)			: 85
RPSU1 SDU PS4 (+5 V) WTG Status				: OK
RPSU1 SDU PS5 (+5 V) STC Status				: OK
RPSU2 SDU PS1 (+15V) Status				: OK
RPSU2 SDU PS2 (+5V) Status				: OK
RPSU2 SDU PS3 (-15V) Status				: OK
RPSU2 SP PS4 (+5V) Status				: OK
RPSU2 SP PS5 (+5V) Status				: OK
RPSU1 SDU PS4 (+5 V) WTG				: 5.000000
RPSU1 SDU PS5 (+5 V) STC				: 5.000000
RPSU2 SDU PS1 (+15V)				: 15.000000
RPSU2 SDU PS2 (+5V)				: 5.000000
RPSU2 SDU PS3 (-15V)				: -15.000000

Figure 10 Portion of RC GUI General Log file

4 Status page

The status of all Radar parameters and their respective subsystems are made available in Status page to facilitate status viewing and monitoring. Status is displayed in the form of easily understandable colour indications i.e. Red indicates NOT OK status, Green indicates OK status and White indicates status not available. Status page is categorized into ‘Transmitter status’ page (Figure 7), ‘Receiver status’ page and ‘Antenna – PDU status’ page.

5 Measurements page

Measured values of all analog parameters of the Radar are brought out in the form of a table in Measurements page (Figure 8). Each analog parameter is categorized under the respective subsystem name in the table to provide readability and understandability. Measurements page also displays the valid range of limits and OK / NOT OK / NA status w.r.t. each parameter.

6 BITE page

Built-In Test Equipment is made available to provide the status of all the Radar subsystems in a single view and enable user-friendly way of troubleshooting.

BITE page (Figure 9) provides the status of Radar subsystems in the form of subsystem blocks. Each subsystem block is placed according to its physical location in the Radar and status is indicated through easily understandable colour indications. Status of all the parameters of each subsystem can also be viewed in the form of a list by clicking on the respective subsystem block.

7 Logs

Log is a vital feature that stores the status of the Radar over a period of time and enables both online and offline analysis and troubleshooting of the Radar and its subsystems. Logs are created and stored in .txt form along with timestamp and are categorized into ‘General log’, ‘Error log’, ‘Custom log’ and ‘Event log’.

- ‘General log’ file (Figure 10) stores last three minutes status of all the parameters categorised under their respective subsystems.
- ‘Error log’ file is created wherever status of any parameter of any subsystem becomes NOT OK. Error log file copies the contents of the General log file and is named after the timestamp of creation of the log file.
- ‘Event log’ records all the events occurred during the operation of RC application along with their respective timestamps.
- ‘Custom log’ records the status of selected set of parameters for specified period of time on User initiation. The logging process can also be stopped by the User whenever desired.

III FUNCTIONALITIES OF RADAR CONTROLLER

RC follows a specified start-up sequence for switching ON the Radar and continues to follow the specified sequence during the operation of the Radar.

RC synchronises all the subsystem parameters by setting them through control command on Power ON. During the operation of the Radar, RC sends control commands to Radar subsystems on User initiation and confirms the acceptance of the command by receipt of acknowledgement.

RC periodically monitors status of the Radar on request basis i.e. RC monitors connectivity of subsystems, health status of subsystems and their respective parameters, status of pre-requisite parameters for operating the Radar and status of interlocks for transmission.

RC also has the capability to intelligently take appropriate action in case of any error and bring the Radar to 'Standby' or 'Not Ready' state, and protect the Radar from any further damage. RC also notifies errors to the User in the form of specific error message in the 'Error message' area. The architecture designed allows seamless parallel execution of functionalities without any interference.

RC has a special feature called as '**Battle short**'. Battle short overrides all the interlocks and enables Radar operation, and is very useful during emergency war conditions.

IV SALIENT FEATURES OF RADAR CONTROLLER

1 Parallel Processing of Radar Controller

RC is an advanced GUI application which is self-sufficient. RC parallelly handles GUI updates, two way communications over UDP with thirteen functional subsystems of the Radar, processes different types of errors and automatically takes appropriate actions, all at the same time in a single application without depending on any extra intermediate hardware or software.

2 Xml files for configuration

RC has a very **flexible architecture** with its wide range of xml files. Xml files in RC are used to configure min, max and default values of Radar parameters, to configure the list of pre-requisite and interlock parameters, for bypassing error checks during testing phase, to configure the list of IP addresses and port numbers for communicating with Radar subsystems, to configure the interval of processing timers etc. The use of xml files for configuration effectively reduces the cycle-time that occurs due to recoding and recompiling of RC application whenever any small change is required.

3 In-built tools

RC provides a wide-range of 'in-built tools' and has effectively eased the design phase, testing phase and enables easy troubleshooting. Inbuilt tools provided by RC eliminate the dependency of external hardware, software tools and operating systems, and makes RC application easily portable and convenient for use. The in-built tools present in RC are as follows:

- In-built '**xml viewer and editor**' (Figure 11) allows user to view and edit various xml files used for Radar parameters configuration.
- In-built 'on-screen numeric and alpha-numeric **virtual keypads**' enable seamless configuration of various Radar parameters on GUI and in xml files using touch-screen. Virtual keypad eliminates the dependency on additional hardware such as mouse and keyboard.
- '**Packet details**' (Figure 12) is a powerful debug tool; it displays the received UDP packet from subsystem in the form of series of bytes in tabular form and eliminates the dependency on external packet capturing tools such as Wireshark while troubleshooting.

- In-built '**file browser**' allows viewing of various files and folders used by RC application and protects access to other folders in the System.
- In-built '**log file viewer**' is a text file viewer which enables viewing of various log files created by RC.
- '**Online calibration**' feature (Figure 13) calibrates the complete Receiver chain and plots dynamic range using in-built '**graph plotting tool**'. The graph plotting tool also consists of zoom-in, zoom-out and navigation buttons for better usability of the graph.
- In-built '**image viewing tool**' enables to save the graphs plotted during online calibration in JPEG format and view the graph for analysis whenever required.

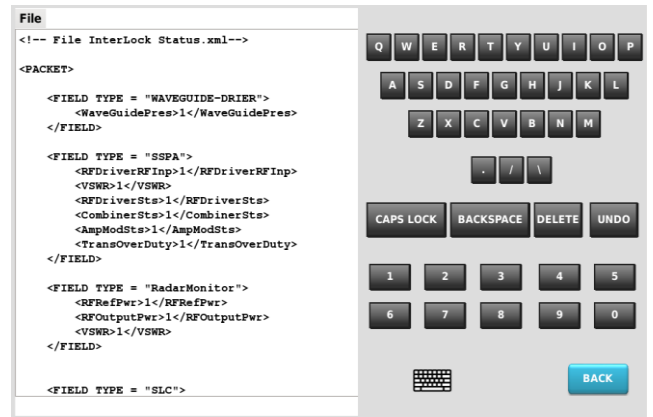

Figure 11 In-built xml file viewer and editor

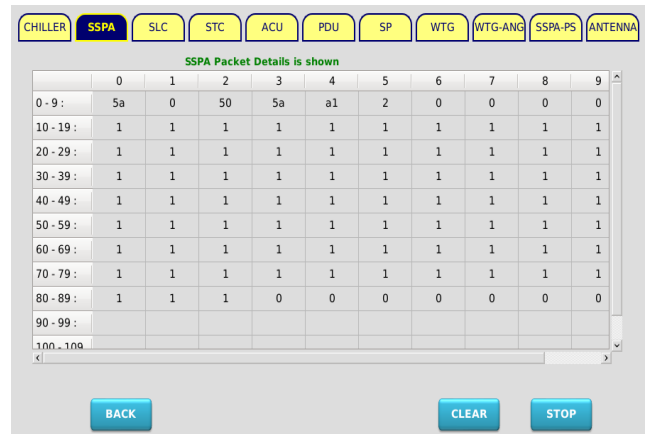

Figure 12 In-built packet details tool

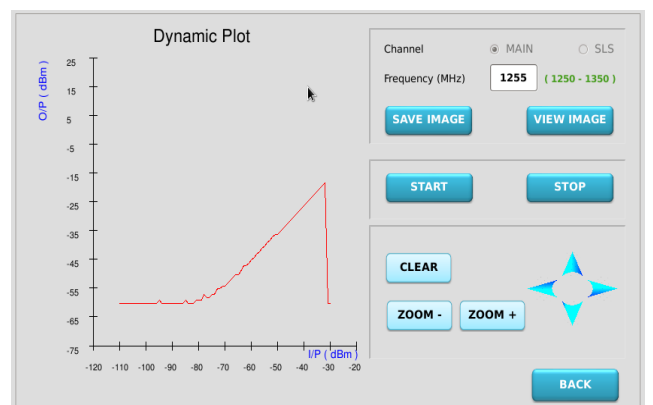

Figure 13 Online calibration feature with in-built graph plotting tool

4 Master / Slave architecture

Master/Slave architecture enables intelligent and seamless automatic takeover of MASTER control of the Radar without any extra intermediate system, when the operating Remote RC fails and ensures continuous operation of the Radar. Status of Radar subsystems can be viewed on any number of passive devices ported with RC application called as 'Auxiliary RC', by connecting them to the Ethernet switch.

Provision exists for control and status monitoring of the Radar using leased line from any remote location with secured authorization. This facility eases fault finding and troubleshooting, and enables assisting customers from any remote location.

5 GUI and Touch-screen

RC application GUI provides appropriate look and feel for User Interface. Status of parameters are indicated using easily understandable colour TABs and makes the Human-Machine Interface (HMI) more user-friendly.

The touch-screen feature of RC eliminates the dependency on external keyboard and mouse, and hence reduction in hardware.

6 Full-fledged Standalone testing

The flexible architecture of RC enables full-fledged standalone testing of Radar Controller functionalities by interfacing with software simulators on standard laptops or desktop computers loaded with Windows XP and above, along with .Net framework. Software simulators were developed on Microsoft Visual studio to facilitate standalone testing of RC.

CONCLUSION

This paper explains the architecture, functionalities, features and convenience of use of Radar Controller software. The Radar Controller application is operational in the Radar RAWL-02 MK-II A deployed in Myanmar onboard ships F-14 and 773 for Royal Myanmar Navy and deployed at INS Dronacharya for Indian Navy. The Radar Control software can be adopted for operation and health monitoring of similar Radars.

ACKNOWLEDGEMENT

Mrs. Dharani B, Sr. DGM, D&E/Naval Systems-2, Bharat Electronics Ltd., constantly provided technical guidance and support during the design and development of Radar Controller in the capacity of Project Manager for RAWL-02 MK-II A Radar and has monitored and reviewed the progress of development of Radar Controller software constantly for its completion. The authors are extremely thankful to the above mentioned Senior Officer.

REFERENCES

- [1] Eric Freeman, Elisabeth Freeman, "Head First Design Patterns" O'Reilly, ISBN 0596007124, 2008
- [2] Erich Gamma, Richard Helm, Ralph Johnson, John Vlissides, "Design Patterns – Elements of Reusable Object-Oriented Software", ISBN 0-201-63361-2, Aug 1997
- [3] Johan Thelin, "Foundations of Qt Development" Apress, 2007
- [4] Jasmin Blanchette, Mark Summerfield, "C++ GUI Programming with Qt4" Printice, 2006
- [5] Aurthur Griffith, "KDE 2 / Qt Programming Bible" IDG Books Worldwide Inc., ISBN 0-7645-4682-1, 2001

BIO DATA OF AUTHORS



Anusha M¹ – B.Tech in Computer Engineering from NIT, Surathkal. Joined BEL in 2014 and is currently working as Dy. Engineer in D&E/RS-NS2. Contributed for development of RAWL-02 MK-II A Radar. Areas of interest include design and development of GUI applications on .Net and Qt, and C (Linux) applications for critical systems.



Sharath L² – B.E. in Electronics & Communication from BMSCE, Bangalore. Joined BEL in 2009 and is currently working as Dy. Manager in D&E/RS-NS2. Contributed in development of C-DWR, RAWL-02 MK-II A Radar, Navigational and Tactical Displays. Areas of interest include System interface design, embedded design, .Net and C applications for critical systems.



Hanamant V M³ – B.E. in Computer Science & Engineering from BVBCE, Hubli. Joined BEL in 2005 and is currently working as Manager in BSTC/C-D&E. Contributed for GUI applications for Radar and Sonar. Has experience in Software SDLC processes and practices. Areas of interest include software application development on Qt.